

ELECTRONICS

and

WIRING SYSTEM (PEN and KAPTON)

CLAUDIO ARNABOLDI
GIANLUIGI PESSINA

Electronic System Scheme

The electronic System consist of many parts we are taking care.

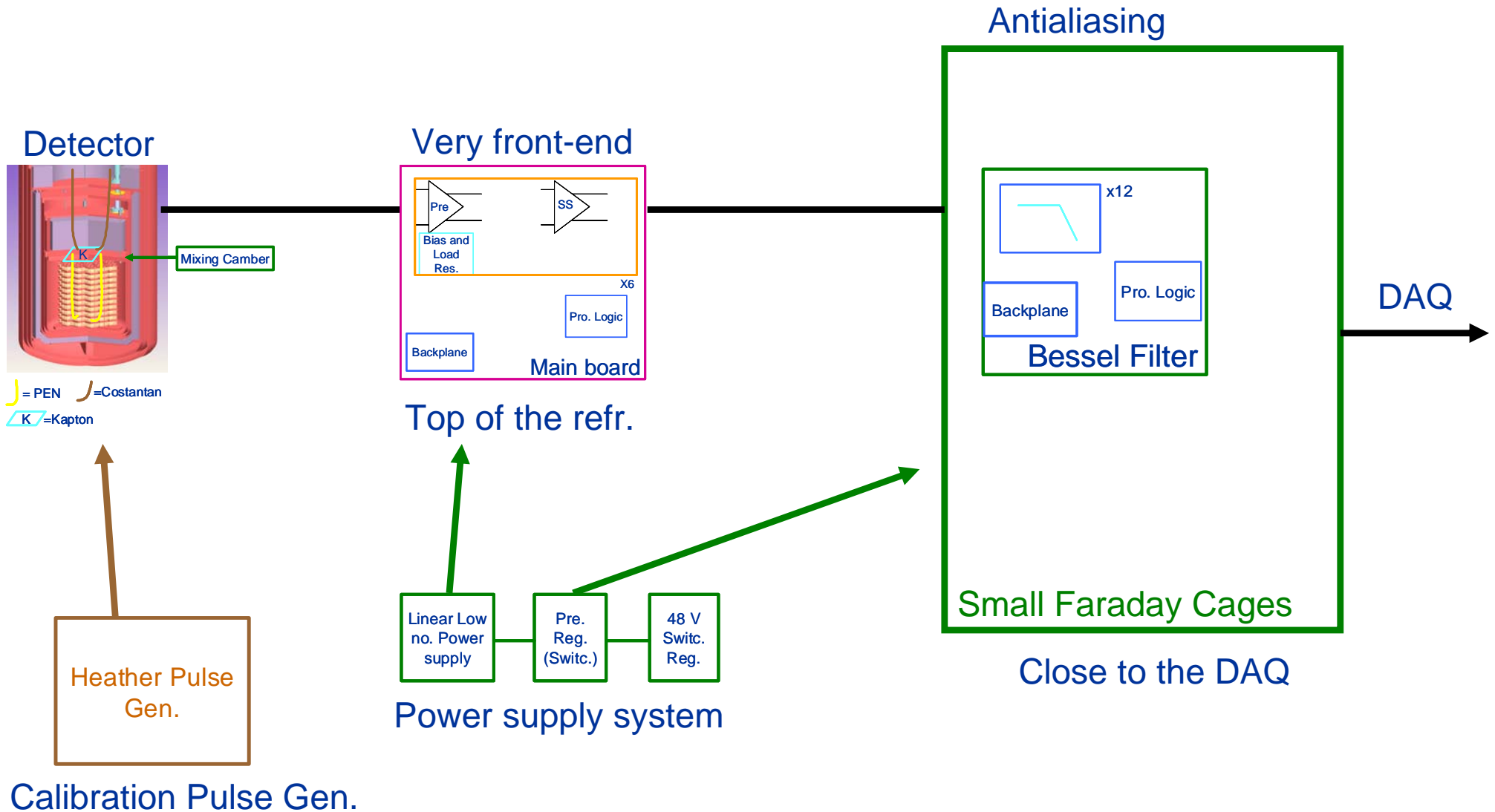

Wiring under the mixing chamber and glue to above mixing chamber I

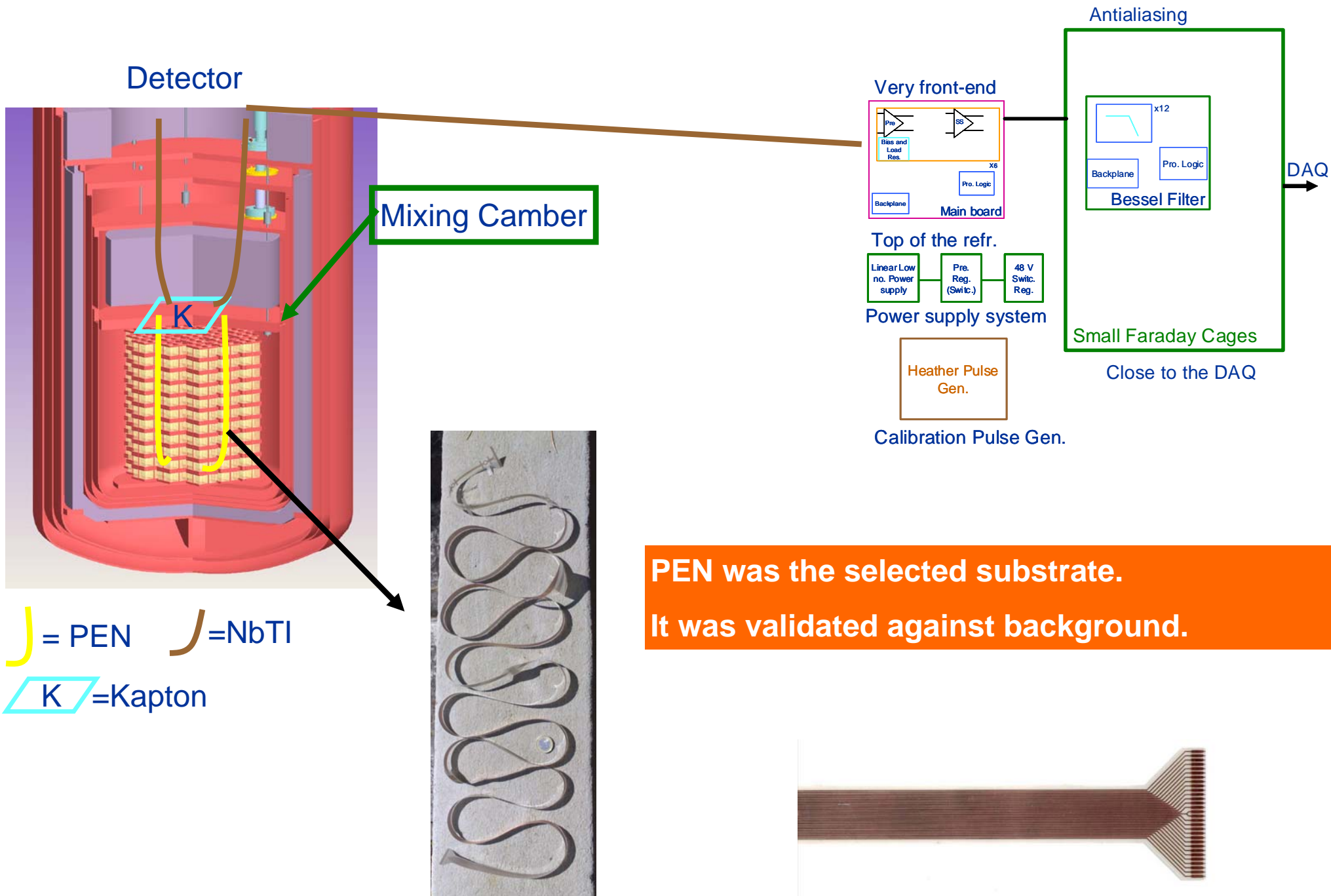

**PEN was the selected substrate.
It was validated against background.**

Wiring under the mixing chamber and glue to above mixing chamber II

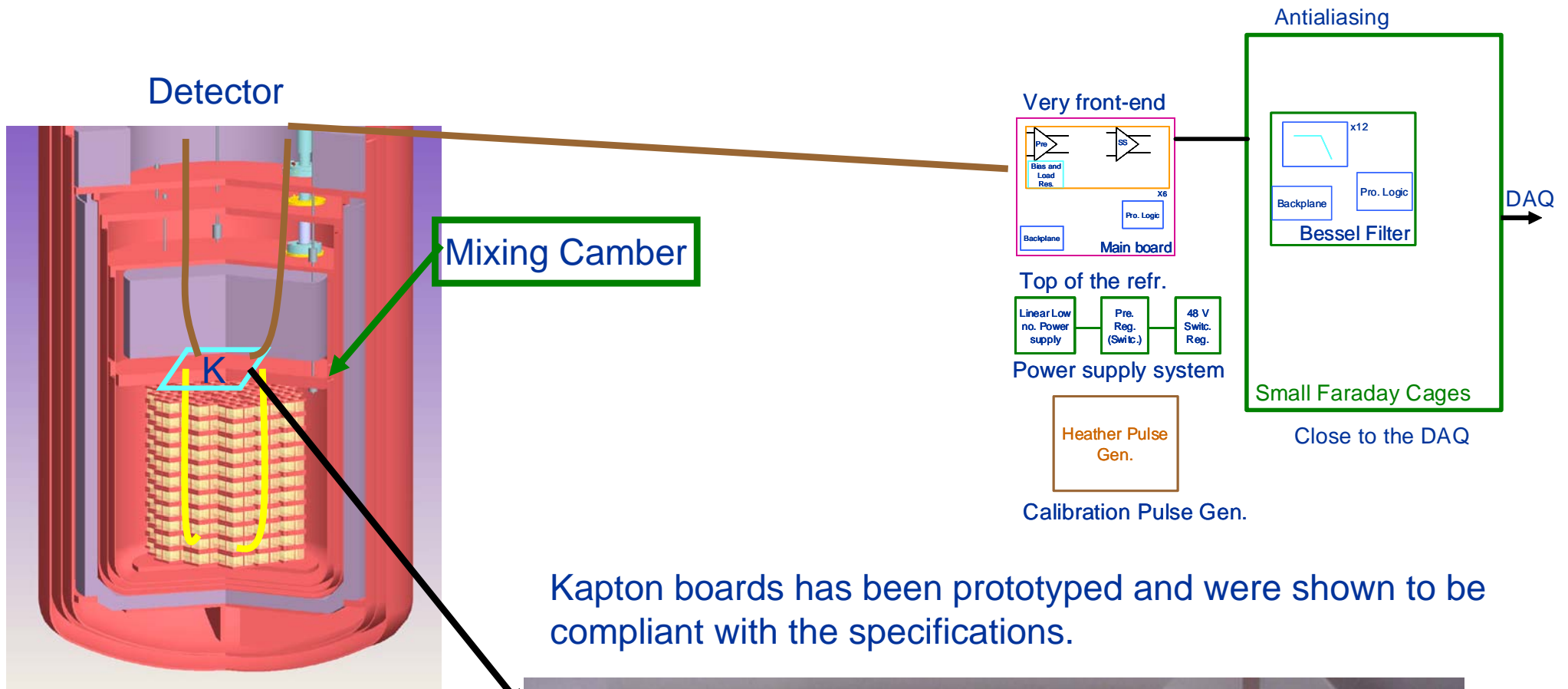

Kapton boards has been prototyped and were shown to be compliant with the specifications.

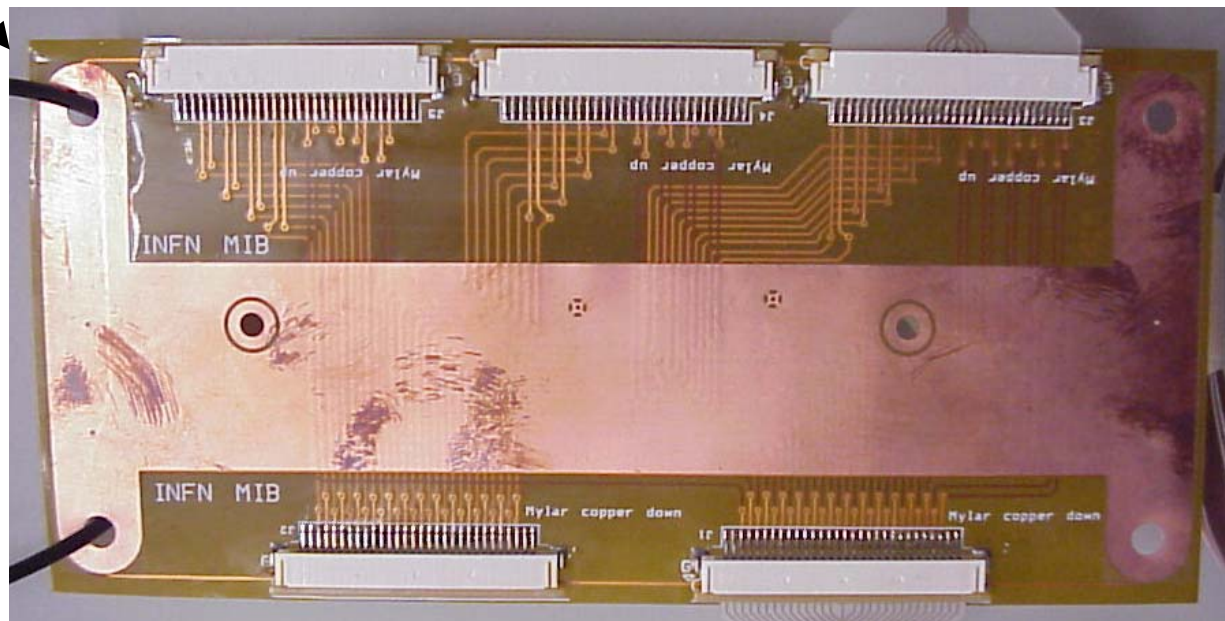

J = PEN J = NbTi
 K = Kapton

Characteristics: 4 layers.
 The tracks are embedded while ground is on the top and bottom.

Wiring under the mixing chamber and glue to above mixing chamber III

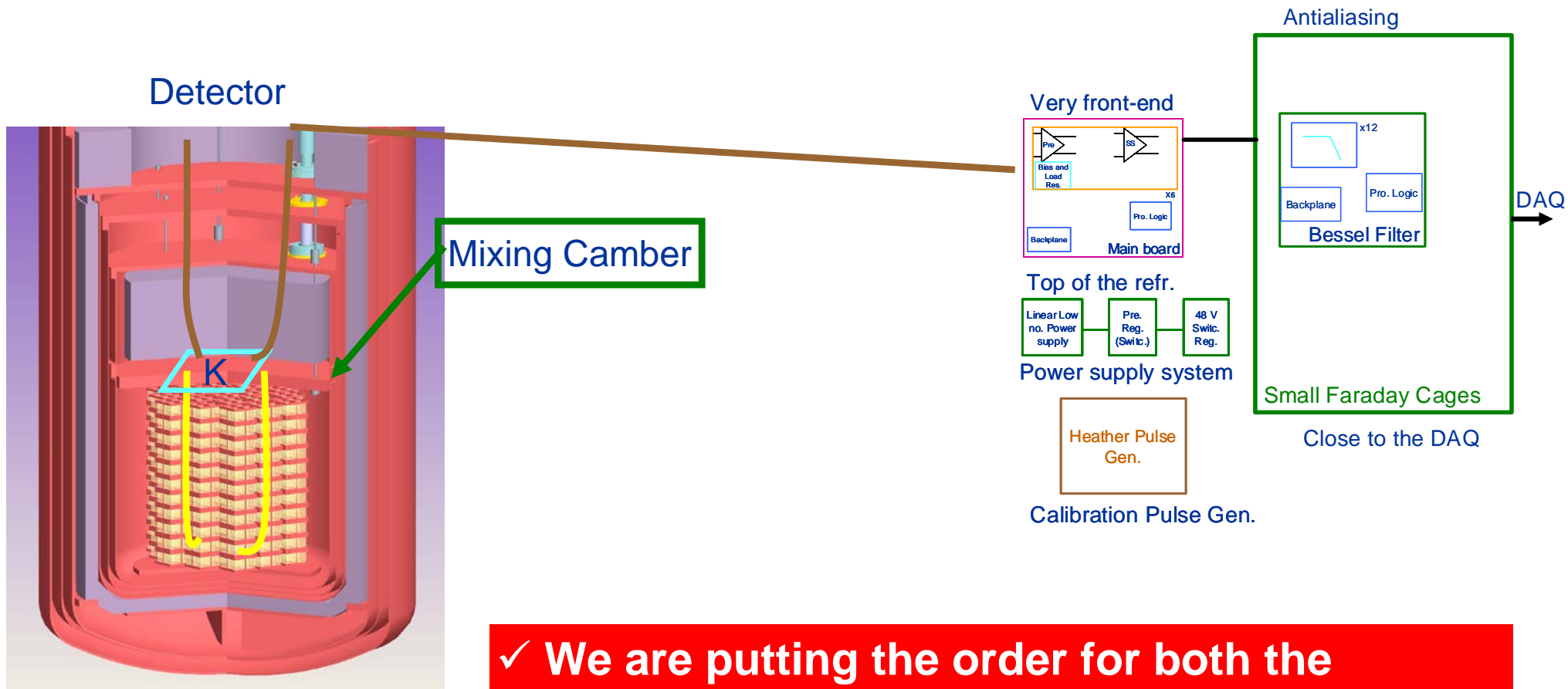

J = PEN J = NbTi
K = Kapton

- ✓ We are putting the order for both the ribbons in PEN and the glue boards in Kapton.
- ✓ Once the finalized layout for all the stuffs will be available (CAW Inputs) the production will start.

Very Front-end

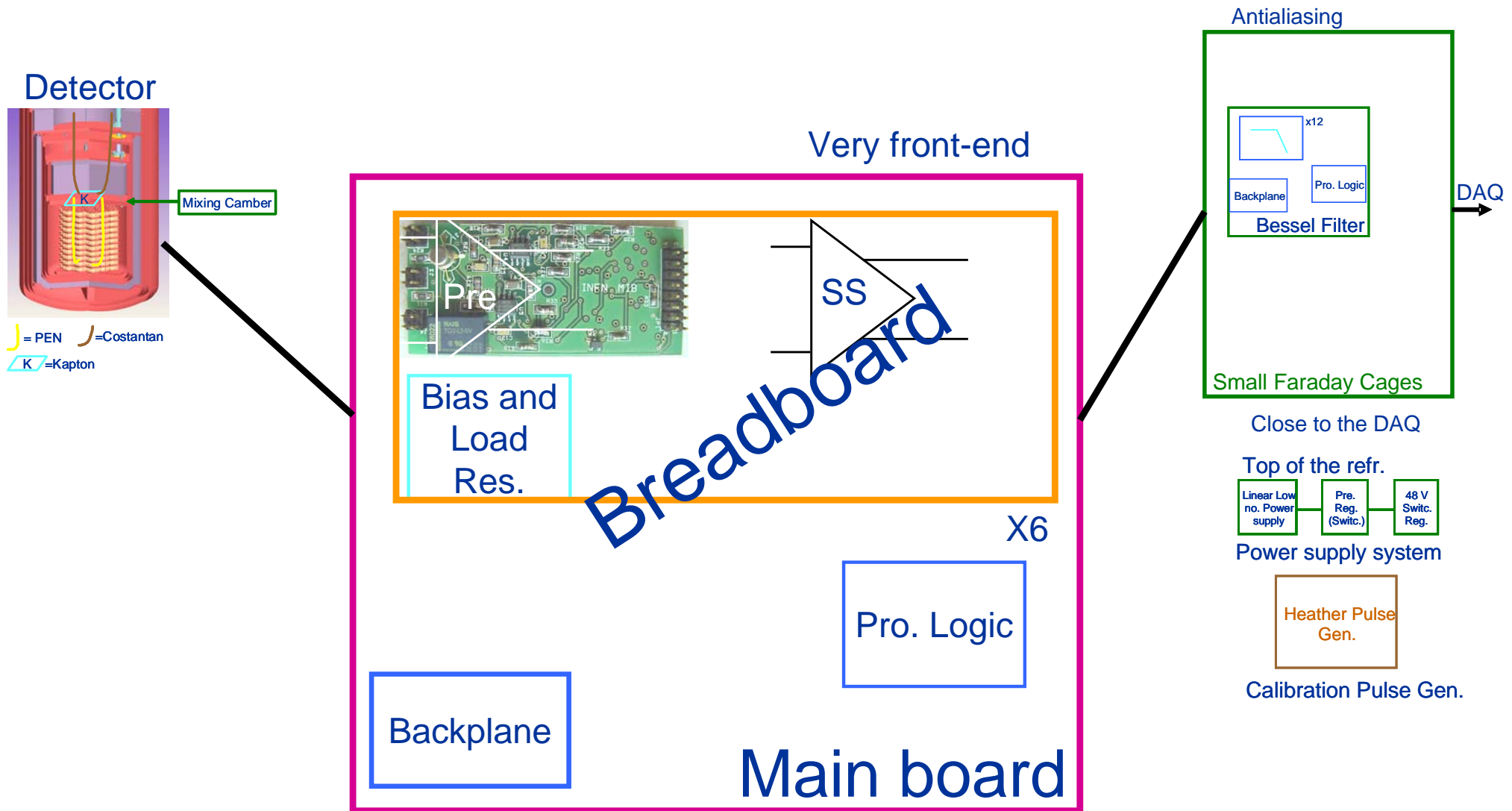

The preamplifier is in the pre-production phase at USC.

The main-board for the very front-end is at the breadboard stage: we estimate about 2 months of delay with respect to the foreseen schedule.

Preamplifier characteristics

- ✓ Differential voltage input – differential voltage output;
- ✓ Two range selectable gain: 212 V/V and 20 V/V;
- ✓ CMRR Adjustable;
- ✓ <100 total fA input current @ 300 K;
- ✓ 3 nV/√Hz white noise, 5 nV/√Hz @ 1 Hz;
- ✓ < 100 nV/C input drift;
- ✓ < 15 ppm/C gain drift;
- ✓ +/- 5 V Voltage Supply.

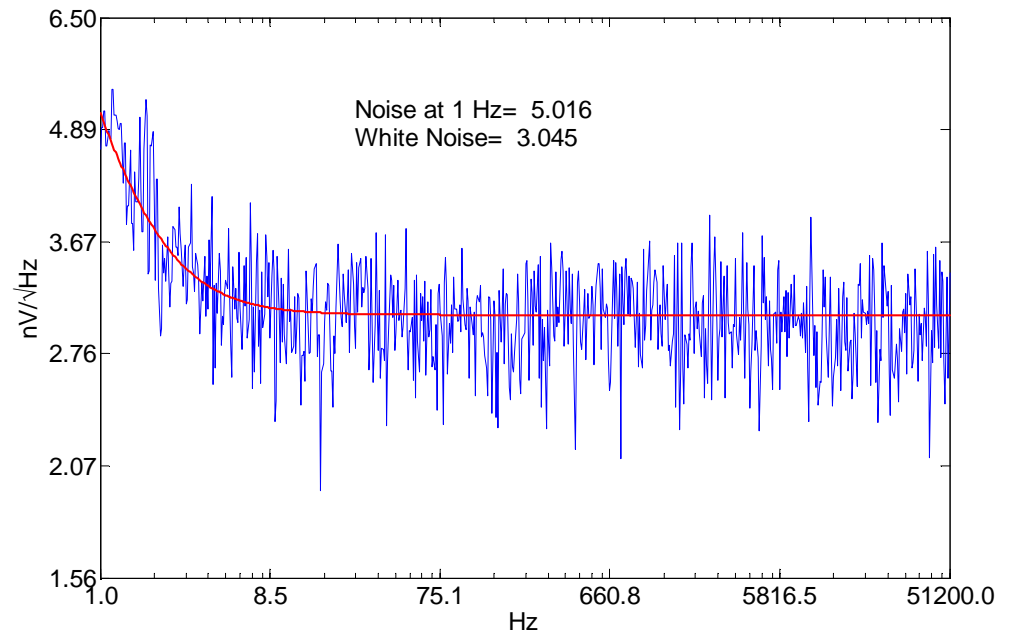
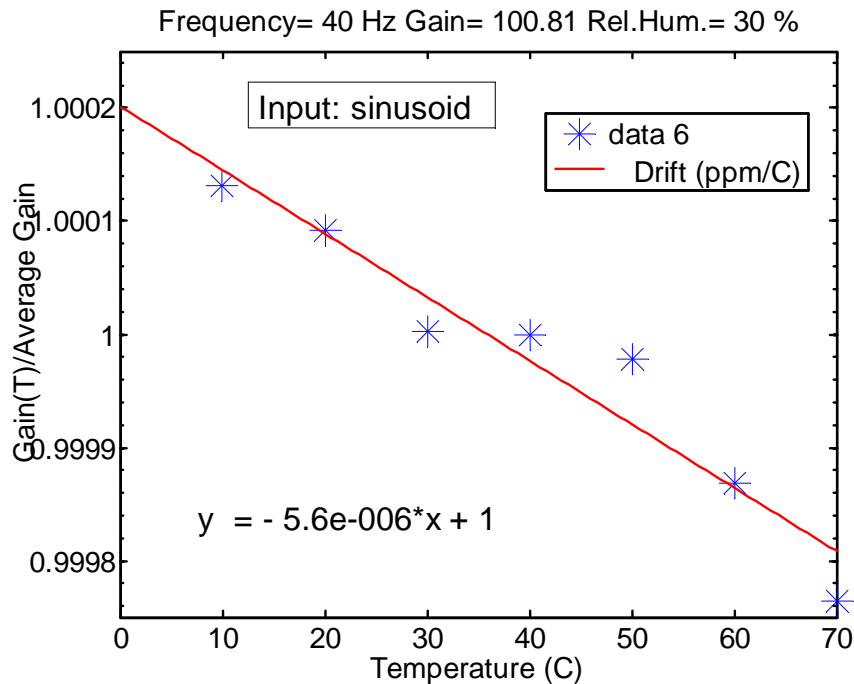
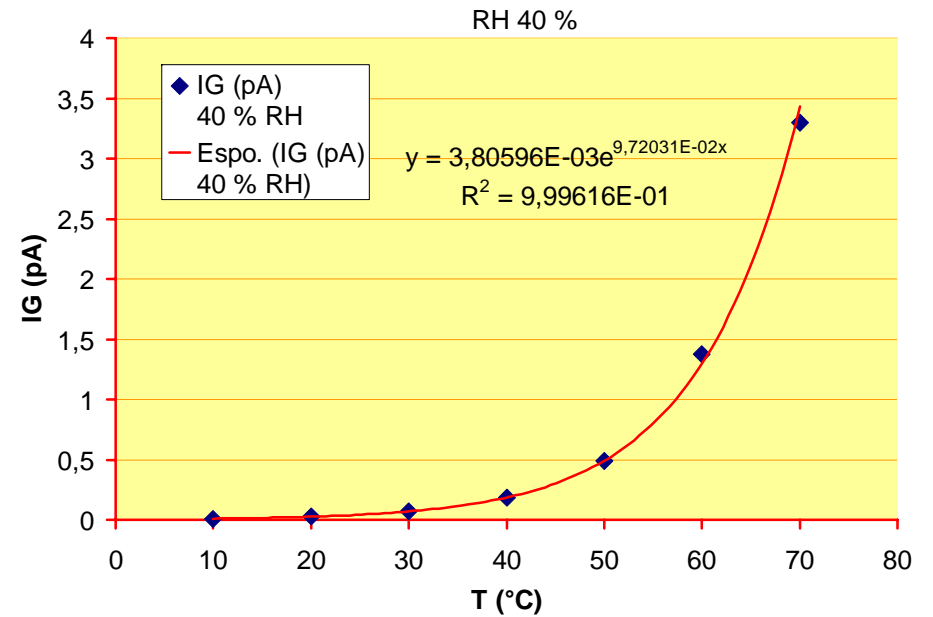

Antialiasing Filter

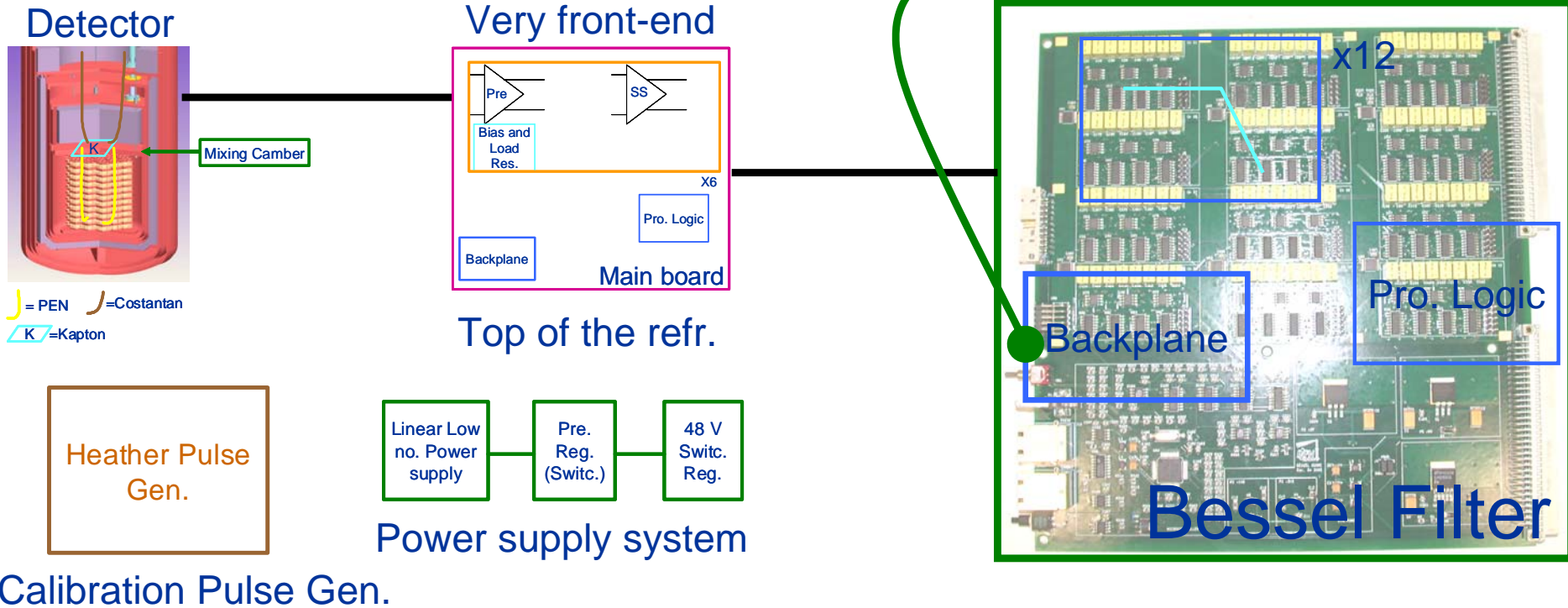

- ✓ The Bessel Filters have been prototyped in Genova. Now they are under final test and optimization (if needed).
- ✓ The backplane for the filters was done.

A preliminary simple firmware has been used to set the working parameters of the channels.

BOARD SPECIFICATIONS

- ✓ 12 Channels per board;
- ✓ 6 poles Low-pass Thomson or Bessel Filters;
- ✓ Filter bypass option;
- ✓ 4 programmable cutoff frequencies: 8 Hz, 12 Hz, 16 Hz and 20 Hz;
- ✓ +/- 9 V Voltage Supply.

The transfer function of the filters has been measured, found consistent with the specs.

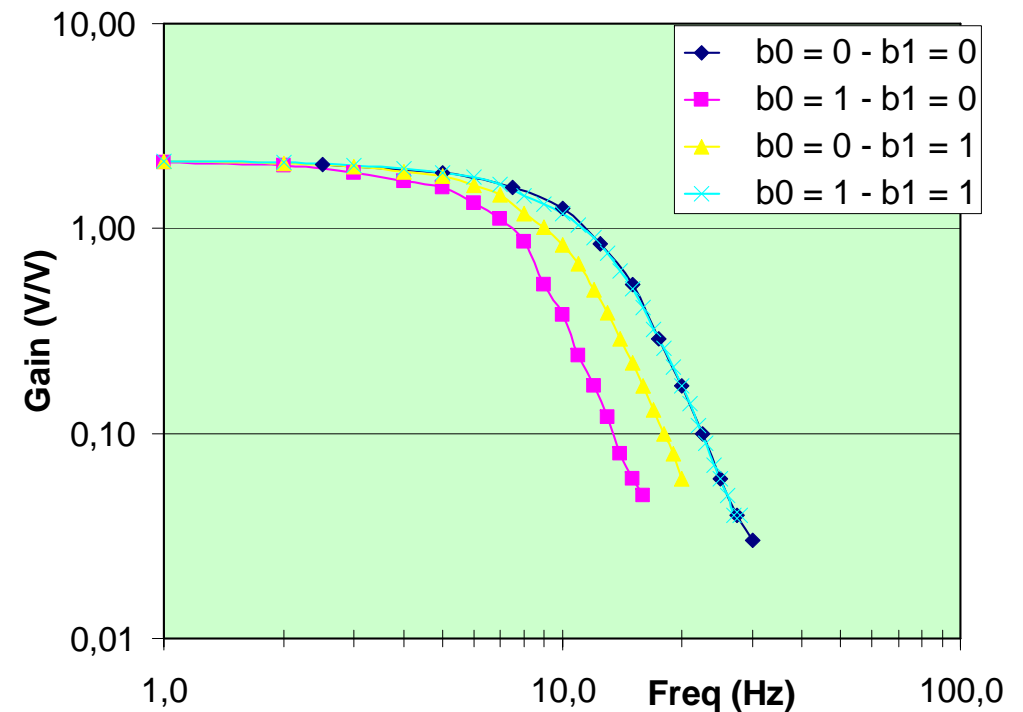

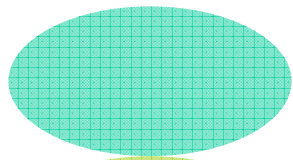
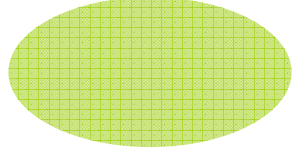
 = finalization and production
 = In progress

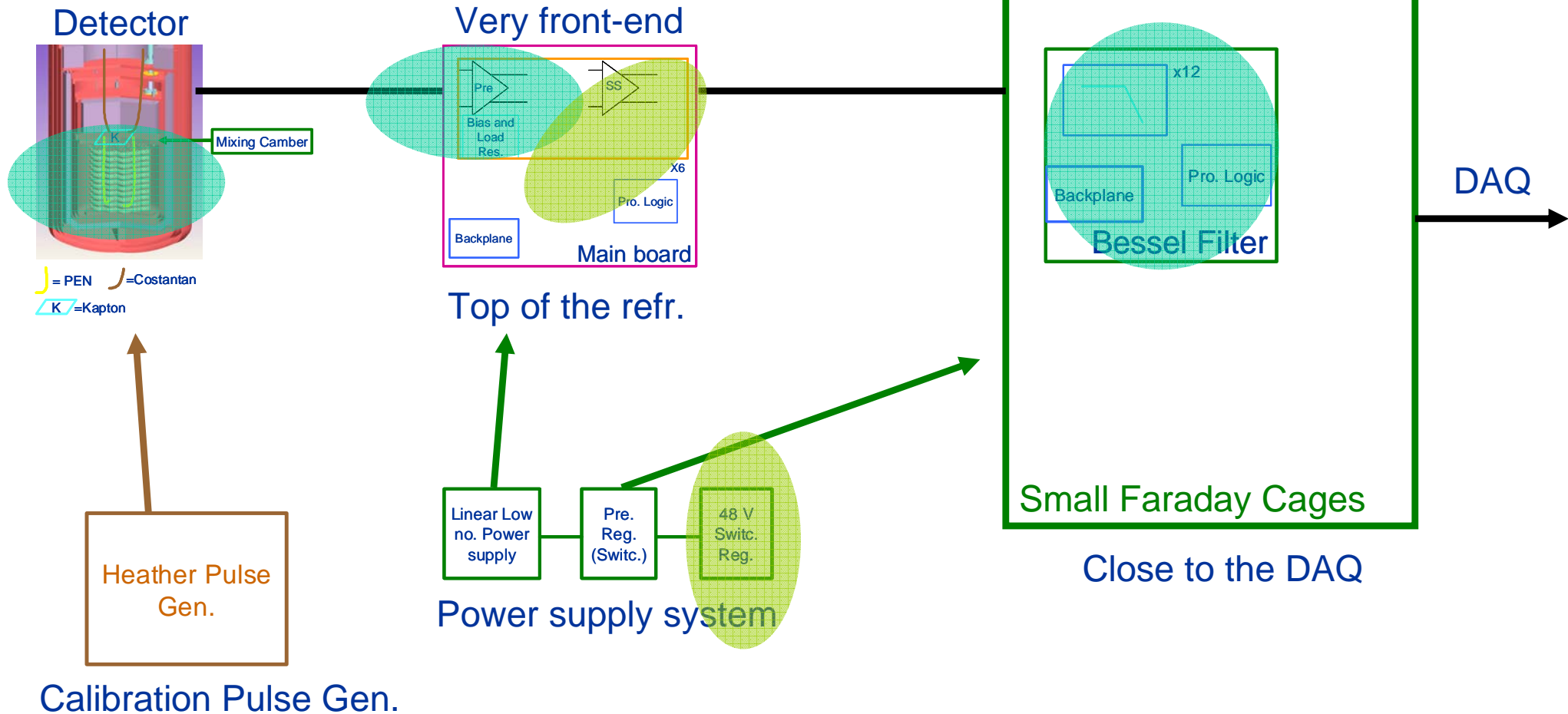

- UCLA is supporting a post-doctoral for 4 – 6 months in MILANO.
- **Xiaohua Liu** is working in developing the system to be used at UCLA for the production characterization and testing.

LIU will give now a short report on the progress of his work.

The sum of the input gate current has been measured vs temperature and Relative Humidity. It was found compliant with what it was expected.

At an operating temperature of 35 °C we have measured about 55 fA per gate, 110 fA of total current.

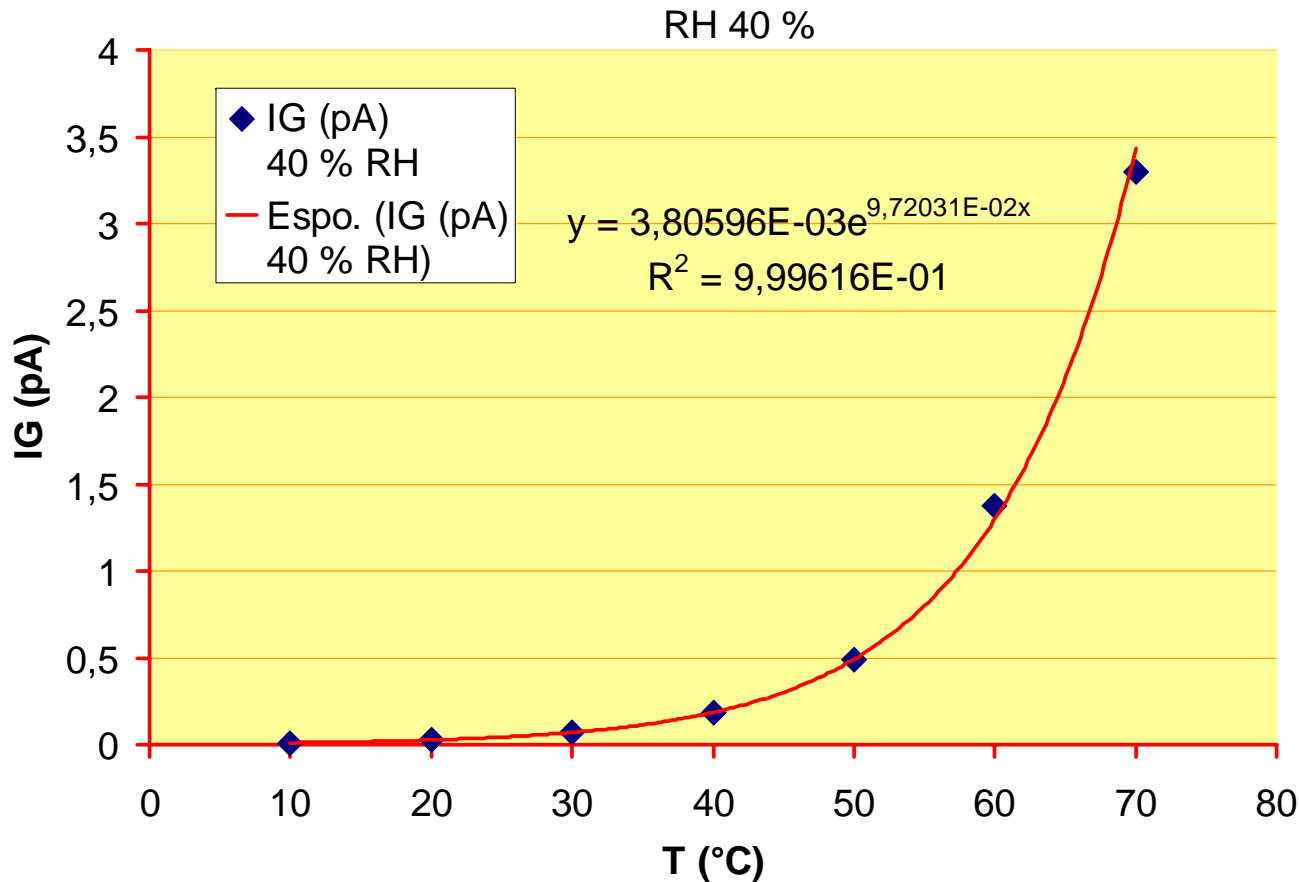
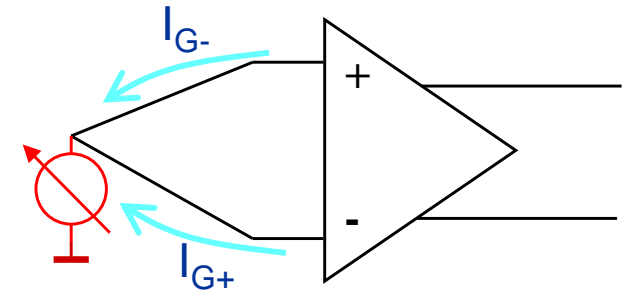

Example:

$Z_B = 100 \text{ M}\Omega$

En Con Gain = $100 \mu\text{V}/\text{MeV}$

Signal Fault time: 300 ms

Limit in resolution from the preamplifier parallel noise only: $200 \text{ eV}_{\text{FWHM}}$

Series Noise

Series noise was also found compliant with the specifications expected.

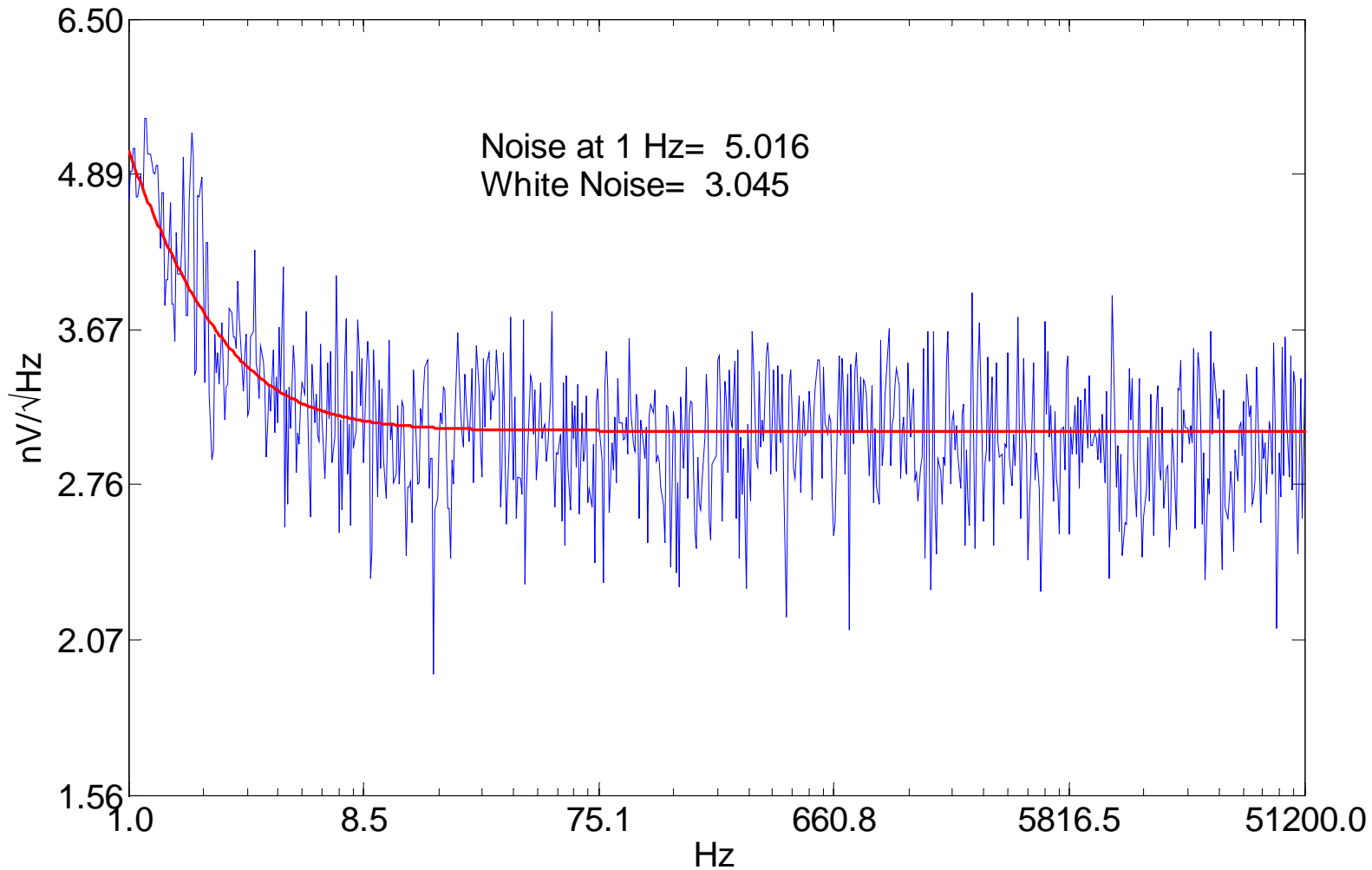

From this source of noise we expect a limit of: $120 eV_{FWHM}$

Gain Drift

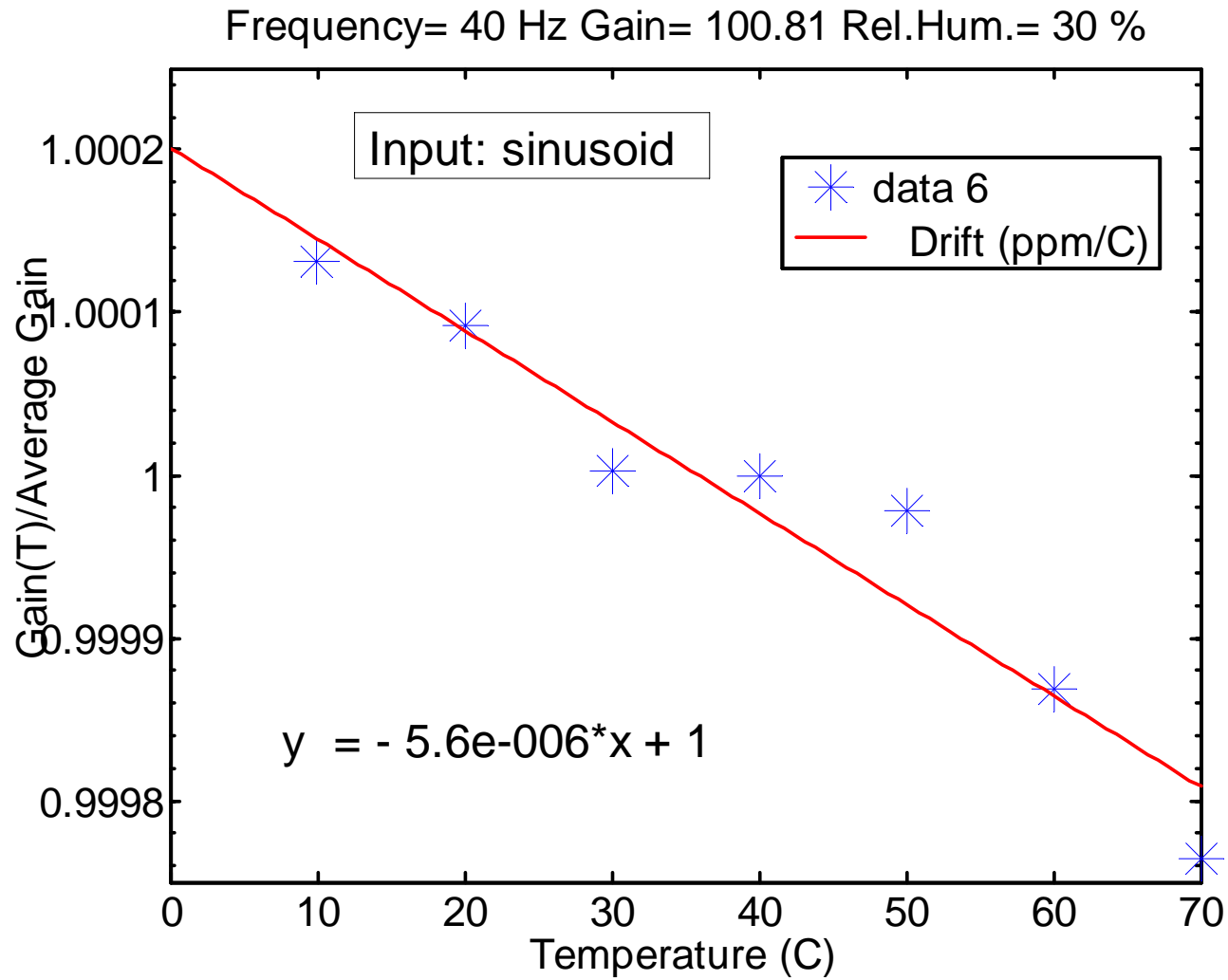

The gain drift is completely compliant with the expected specifications.

